

Art Virtual Learning

8th grade Art 3

April 15, 2020

Take a closer look at a Famous Artist and their work

Explore a technique or Artist happening somewhere in the world right now!

Figure drawing challenges

Masterpiece Monday

Technique Tuesday

What's Up Wednesday

Thumbnail Thursday

Finally Friday

Practice Skills Known and new techniques

Small, loose sketches of objects we find or design concepts



Lesson: **April 15**
Objective/Learning Target
I can study the print making technique, etching, and create my own idea.

What is Etching?

Etching is a printmaking process where the artist scratches onto a metal plate. Acid, wax, and special ink are all involved in this process. The plate is rolled through a press and the image appears on paper!

The soldier and his wife by Daniel Hopper.



The science

Etching is as much a science as it is an art.

- 1. The artist draws with a sharp tool on to a copper, zinc, or steel plate that has been covered with an acid resistant wax. When the plate is soaking in acid, the bare metal, exposed by the lines of the drawing, is eroded. The longer in acid, the deeper the line and the darker it will print. They then smear greasy ink over the entire plate**



2. Once the ink is in all of the etched grooves, the surface is wiped clean, leaving only the etched areas retaining ink. The plate is placed on a flat bed, covered with *dampened* paper, and backed with three or four felt blankets

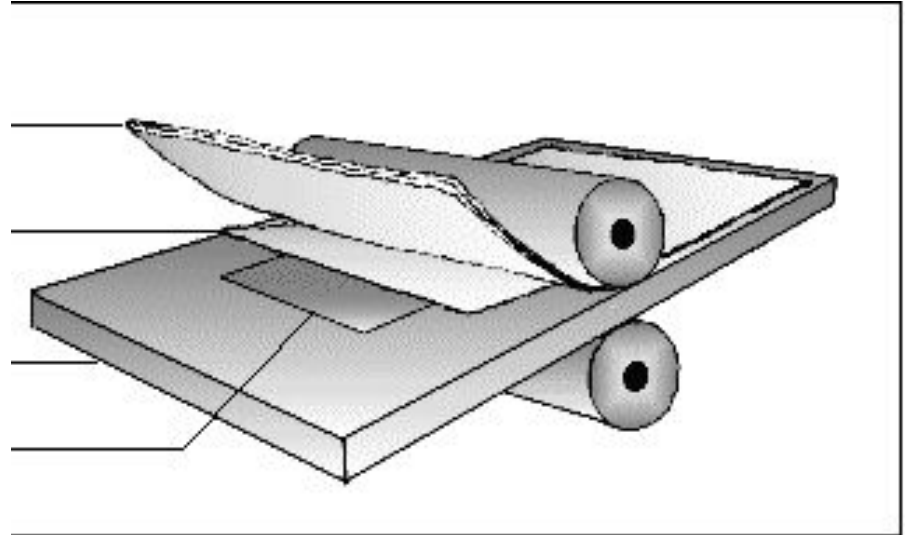

3. These are then passed through the press under high pressure, the damp paper is forced into the cuts and ridges in the plate and picks up the ink. When the paper is finally peeled off, it reveals a mirror image of the etched drawing. This inking procedure is then repeated for each print.

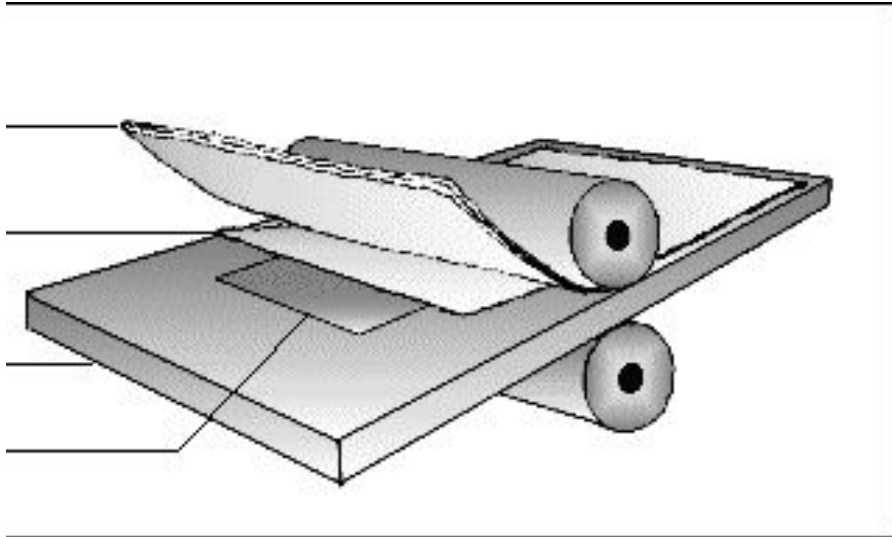

Watch this traditional
Artist Use the etching
process! ETCHING

Yesterday we studied cross hatching.

Why would this method of shading be helpful for an artist who is printmaking?

Young Girl in cafe with street-view,
etching by Lesser
Ury, 1924



Cross hatching was a great way to show shading when an artist couldn't simply blend a pencil.

Young Girl in cafe with street-view,
etching by Lesser
Ury, 1924



Etching was used to make prints. Another and very common way we see etching was in metal such as weapons and armor. Some people today etch their knives or tools. You can even etch glass!





Etching today

While some artists still use the traditional methods, others have more modern ways to etch. Watch this video to see how these knives become works of art!

[click here for knives video](#)

Let's say you're an artist whose specialty is metal etching. A customer has asked you to etch a knife. This customer wants the knife to represent sailing, his Grandfather's past time. Draw your own template, then the design you would include!



HOW TO SHOW US YOUR CREATIONS...

*BE BOLD, BE SAFE, and
TAKE CARE OF YOU!*

*All the best,
Ms. Perez*

We'd love to see your
work!!!

Email your art teacher and
be sure to tag your
principal as well.

sarah_perez@idschools.org